

EN

GEM-ACC-KP installation guide

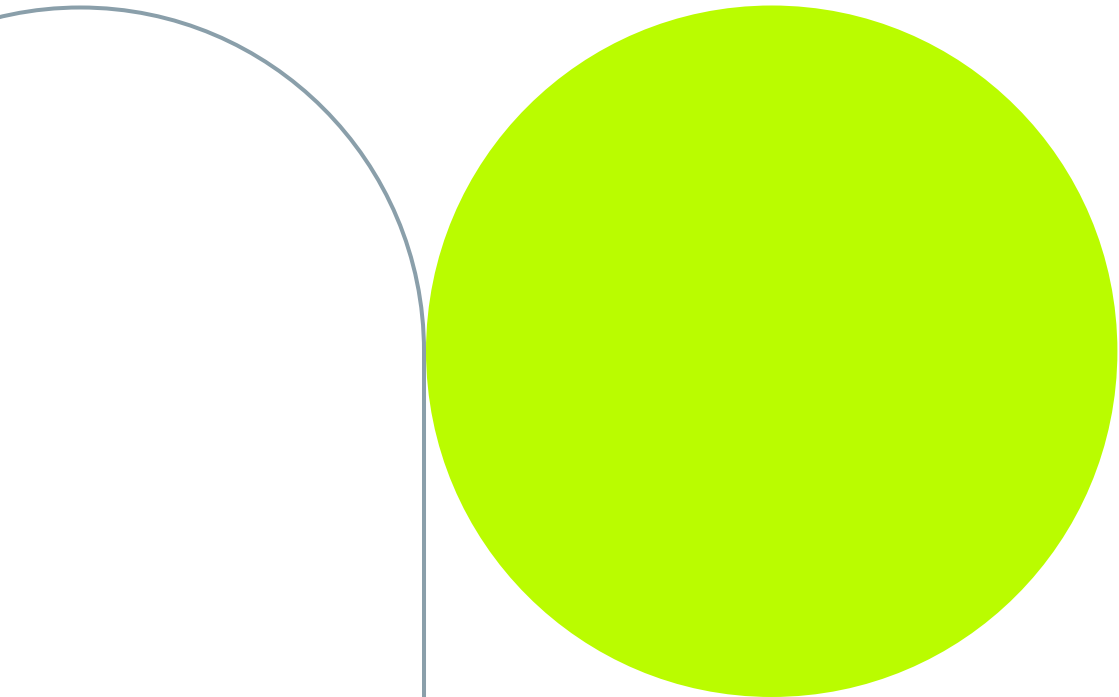

GemOne®



Content

General information	4
Technical specs	4
Dimensions	5
Wiring	5
Installation	6
Which signal to interrupt?	7
Relay selection	10
Installation schematics	11
GEM-OX-L	11
GEM-OX-C	12
9-80V Absolute max	
/12-66V Nominal	12
80-97V Absolute max	
/66-80V Nominal	13
GEM-OX-G	14
Telematics connector	15
How to use	16
Unblocking a machine	16
Blocking a machine	16
FAQ / Troubleshooting	17
Support	20
Warranty	21

General information

The GemOne RFID keypad adds driver identification and access control to your existing fleet. The waterproof design allows you to install this on both indoor and outdoor machines, independent of the machine model. It is compatible with a wide range of GemOne products, including the Onyx product family. Drivers can authenticate themselves using

their personal PIN code or using a mix of RFID technologies such as HID, EM and MIFARE. The built-in LED and buzzer provide immediate feedback to the user, even in a noisy environment. Our GemOne cloud platform allows you to easily manage and assign cards and PIN codes to the different machines, without physical access to the machines.

Technical specs





Dimensions	4.8 (L) x 1.96 (W) x 0.8 (H) inches
Voltage range	9-80V Absolute max / 12-66V Nominal
Supported card types	HID 26-bit EM 26-bit MIFARE Classic 1k
IP rating	IP67
Temperature range	-22°F - 140°F
Weight	4.93 ounces

Dimensions

4.8 (L) x 1.96 (W) x 0.8 (H) inches



Wiring

Wire color		Connection	Description
Red		Bat+	Attach to permanent 2-66V power supply (9-80V absolute max)
Black		Ground	Attach to the ground of the machine
Green		1-wire	Attach to the 1-wire data from the tracker
Yellow		Feedback	Attach to the correct Dout from the tracker

Installation

The ACC-KP is an add-on on your existing Onyx tracker. Make sure to consult the installation manual of the relevant tracker before installing the keypad!

If you are using our OX-C product, do NOT connect DIN3 and DIN4 to the machine when using access control or remote ignition blocking. These wires get reconfigured as outputs and should only be used to drive the relays, as indicated on the schematics in this manual. Damage may occur to the machine and/or telematics device if DIN3 or DIN4 are connected to a signal from the machine if access control is enabled via the GemOne web portal.

The tracker monitors the ignition key using the DIN1/ACC to decide when the engine has to be blocked or not:

- When the ignition is off: the engine is not blocked to reduce battery drain
- When the ignition turns on: the digital output is activated to actively block the ignition until the driver presents a valid card or PIN code

Which signal to interrupt?

For machines with a combustion engine, the easiest way to block the engine is by interrupting the starter engine. Always make sure the current through the ignition blocking relay never exceeds the advertised maximum (for example 15A for 24V or 30A for 12V relays). If the starter motor uses more current, check if the starter relay can be interrupted instead of the motor itself.

Some vehicles (e.g. electric forklifts) don't have a starter engine. In that case, the ignition blocking relay could be wired to one of the following items:

- Driver seat switch
- Driver seat belt switch
- Charging switch/input
- ...

Make sure you never circumvent any of the safety features of your machine; always consult your vehicle's technical manual.

It's not recommended to directly interrupt the key switch, always interrupt the coil to the starter engine, driver seat switch, seat belt switch, charging input, ... but in some cases, interrupting the key switch is the only option.

The relay should never interrupt the key switch signal going to digital input 1. The ignition signal should always be available to the telematics unit, even if the machine is immobilized by the relay.

If the device is installed incorrectly (the key switch signal on digital input 1 drops as soon as the blocking relay activates) then a feedback loop is created, causing the machine to block and unblock in an endless loop:

- Ignition signal is detected on Din1
- The blocking relay is activated
- The ignition signal is interrupted on Din1 because of a wrong installation.
- The blocking relay is deactivated
- The ignition signal is present again since the relay is inactive
- The blocking relay is activated again
- ...

Keep in mind that interrupting the key switch signal on digital input 1 could happen by mistake either directly - by wiring the relay before the digital input, or indirectly - if the machine takes away the ignition signal when the blocking relay is active. Both situations must be prevented.

If your machine has no other option except for interrupting the key switch, then make sure to connect digital input and the relay in the correct order. See next page for a good and a bad example.

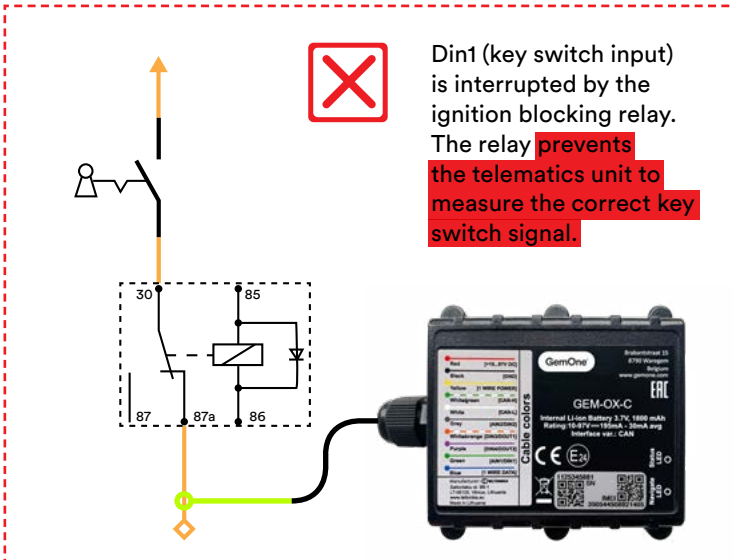
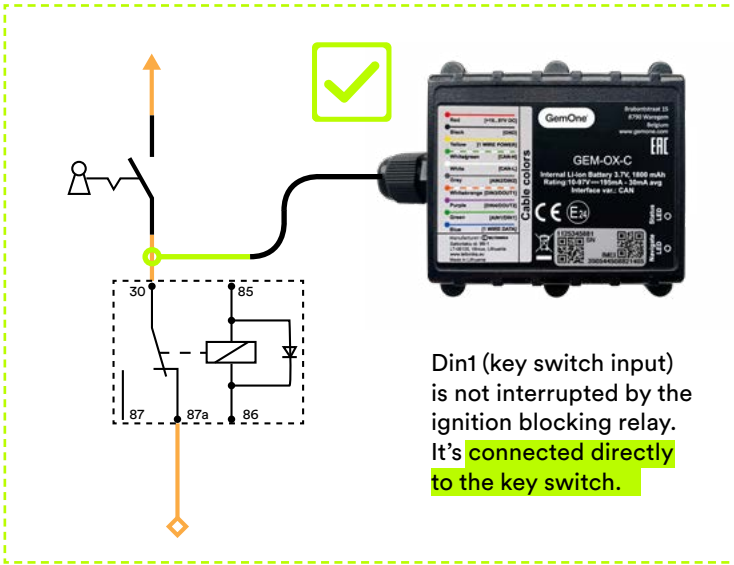

Relay selection

The tracker assumes that a normally closed relay is used. When the ignition is off, the tracker does not activate its digital output and the relay stays closed to prevent battery drain. When the ignition is on, the tracker activates its digital output and the relay opens to block the machine, until the operator signs in by entering a PIN or reading the RFID card.

Always make sure that you choose the correct relay for your machine. The coil voltage of the relay needs to be compatible with the machine's battery (12V relay for 12V machines, 24V relay for 24V machines, etc.). Furthermore, to protect the tracker from voltage spikes, the relay must also include a flyback diode. With a flyback diode, the polarity of the coil is important: Bat+ must be connected to the cathode of the diode (relay pin 86) while the digital output must be connected to the anode (relay pin 85).

Installation schematics

GEM-OX-L



Make sure to use a normally closed relay that is compatible with your machine's battery and includes a flyback diode. See section 'Relay selection'.

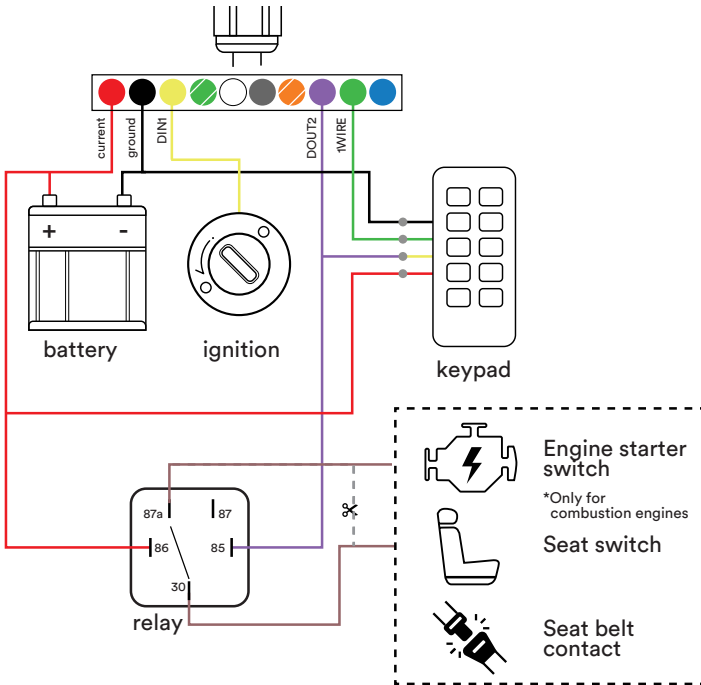

GEM-OX-C

9-80V Absolute max / 12-66V Nominal



Make sure to use a normally closed relay that is compatible with your machine's battery and includes a flyback diode. See section 'Relay selection'.

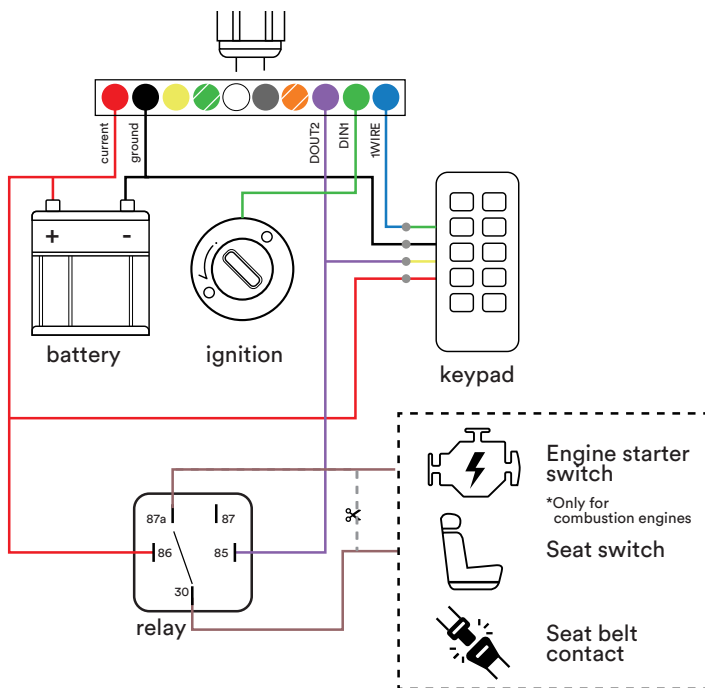

GEM-OX-C

80-97V Absolute max / 66V-80V Nominal



Make sure to use a normally closed relay that is compatible with your machine's battery and includes a flyback diode. See section 'Relay selection'.

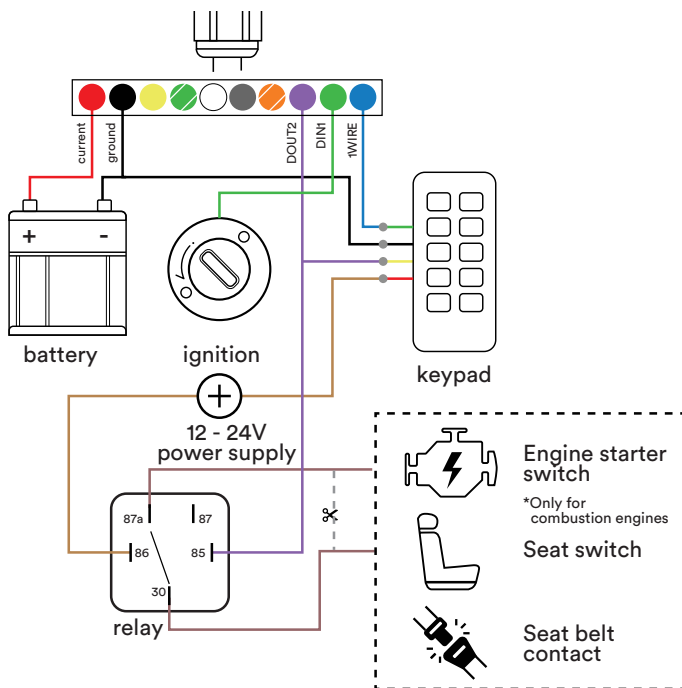

GEM-OX-G



Make sure to use a 12V normally closed relay with a flyback diode. See section 'Relay selection'.

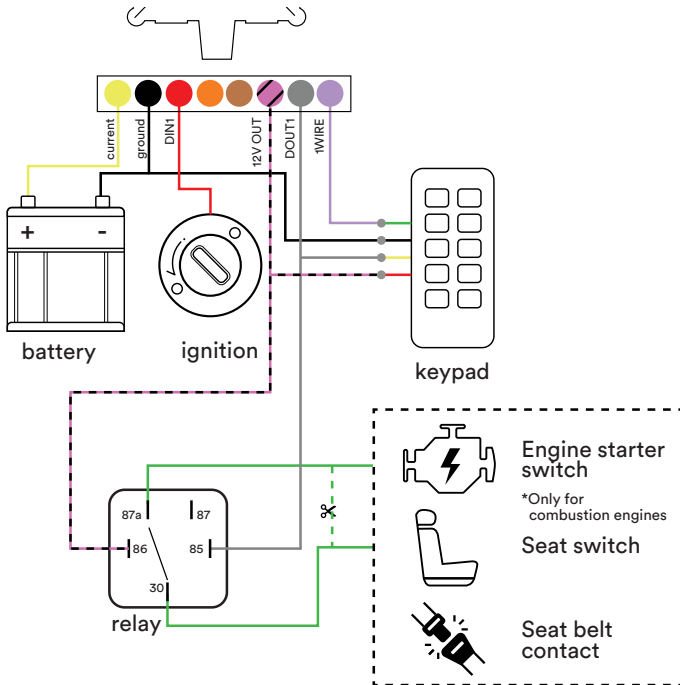

Telematics connector

Some machines have built-in support for ignition blocking. Models like this have a specific telematics connector or wire that allows the telematics module to block the machine in a safe manner.

We can divide these machines into 2 categories: models with active HIGH or active LOW blocking.

- Machines with active HIGH blocking will disable the ignition when Bat+ is applied to the 'remote machine disable' wire.
- Active LOW blocking on the other hand will disable the ignition when the 'remote machine disable' wire is connected to ground (chassis or Bat-).

Make sure to consult your machine manual for model-specific installation instructions.

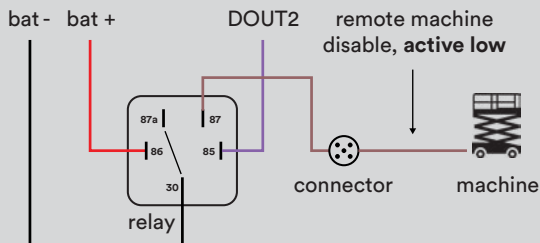
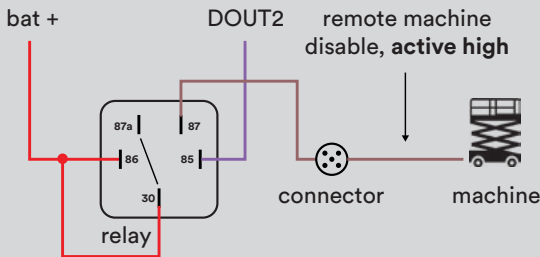

How to use

Unblocking a machine

When a machine is equipped with access control, a driver should use the following steps to unlock the machine:

- ① Turn on the ignition using the key switch or on/off switch of the machine.
- ② The tracker will now actively block the machine. This is indicated by the red LED on the keypad.
- ③ To unlock the machine using a PIN code, enter the correct PIN code and confirm by pressing the # sign.
- ④ To unlock the machine using an RFID card, hold the card on top of the buttons of the keypad. The keypad will provide a short beep when the card is detected.
- ⑤ If the PIN code or card was accepted by the tracker, the LED will turn green and the keypad will beep for 5 seconds. The machine is now unblocked and can be operated.

Blocking a machine

- ① To end your session on the machine, turn off the ignition using the key switch or on/off switch. The LED stays green when the session ends.
- ② To operate the machine again, the unblocking procedure needs to be used as described above.

FAQ / Troubleshooting

My machine is not blocking.

- **Is the tracker powered correctly?**
In order for the tracker to function correctly, it needs to be connected to a permanent power supply.
- **Is the ignition signal wired correctly?**
Make sure the ignition is connected and turned on. Turning on the ignition is vital, as the tracker will only start blocking the machine once the ignition signal is detected. DIN1/ACC of the tracker needs a positive voltage in order to block the machine.
- **Is access control enabled on the GemOne cloud platform?**
In order for access control to be enabled on the tracker, cards or PIN codes need to be assigned to the corresponding machine on the GemOne cloud platform. If no cards or no PIN codes are assigned to the machine, access control is disabled on the tracker.
- **Was the correct relay selected?**
Make sure that the voltage of the relay coil matches with the used supply to trigger the relay. See 'Relay selection' for more information.
- **Is the relay correctly powered?**
Pin 86 should be connected to the power supply and not to the output of our tracker. This is because the relay has an internal flyback diode. The digital outputs of our tracker will only switch between the 'floating' and 'pull to ground' states - so it needs to be connected to pin 85 of the relay.
- **Is the relay interrupting a relevant wire to block the machine?**
There is sometimes confusion about the cable going from the ignition to the engine. This wire should be cut in two. The first part goes from the ignition to the relay (pin 87a). The second part goes from the relay (pin 30) to the engine.

The LED of the keypad is off, pressing keys or presenting a card does nothing.

- **Is the power to the keypad wired correctly?**
Make sure the keypad is correctly powered using 9-80V Absolute max / 12-66V Nominal between the red (Bat+) and black (ground) wires.

My machine is unblocked, but when I enter a PIN code or present the correct card it starts blocking?

- **Is the normal closed contact used to interrupt the machine?**
Since the tracker only actively blocks - the relay should use the NC contacts to interrupt the machine (pin 87a, not 87).

Blocking and unblocking works, but the LED always stays green.

- **Is the feedback wire connected properly?**
The RFID keypad reader will provide user feedback (LED and buzzer) based on the input from the yellow wire. If this wire is not connected to the correct output of the tracker, feedback will be missing - resulting in an always green LED and no sound.

My machine is blocked, but cannot be unblocked.

- **Is the 1-wire data line connected?**
Make sure the green wire of the keypad is connected to the tracker. This wire is used to communicate the PIN code or card to the tracker.
- **Is the correct card type used?**
If the reader doesn't give a short beep while presenting your card, the card is not supported. See 'Technical specs' to get a list of supported cards.
- **Is the RFID card presented correctly?**
Make sure to hold the RFID card in front of the keypad buttons. Keep the card there for a moment until you get the short feedback beep.
- **Is the used PIN or card allowed access?**
Cards or PIN codes need to be assigned to the corresponding machine on the GemOne cloud platform before they can unlock the machine.

My machine keeps blocking and unblocking as soon as I turn on the key switch.

- **Is the relay and Din1 connected properly?**
Make sure the blocking relay is not interrupting the ignition signal on digital input 1. The tracker should always see an active ignition signal, even if the machine is immobilized. See 'Which signal to interrupt' for more information.

Support

In case of issues, questions or feedback, feel free to contact our support team.

 +1-844-275-2801

 techservice@gemone.com

Save time with our connectors

Request connectors for your machines to save time while installing our trackers. GemOne offers a multitude of different connectors. Get in contact with your account manager for an offer.



Warranty

Our warranty does not cover any damage resulting from unauthorized modification or wrong installation of the product.

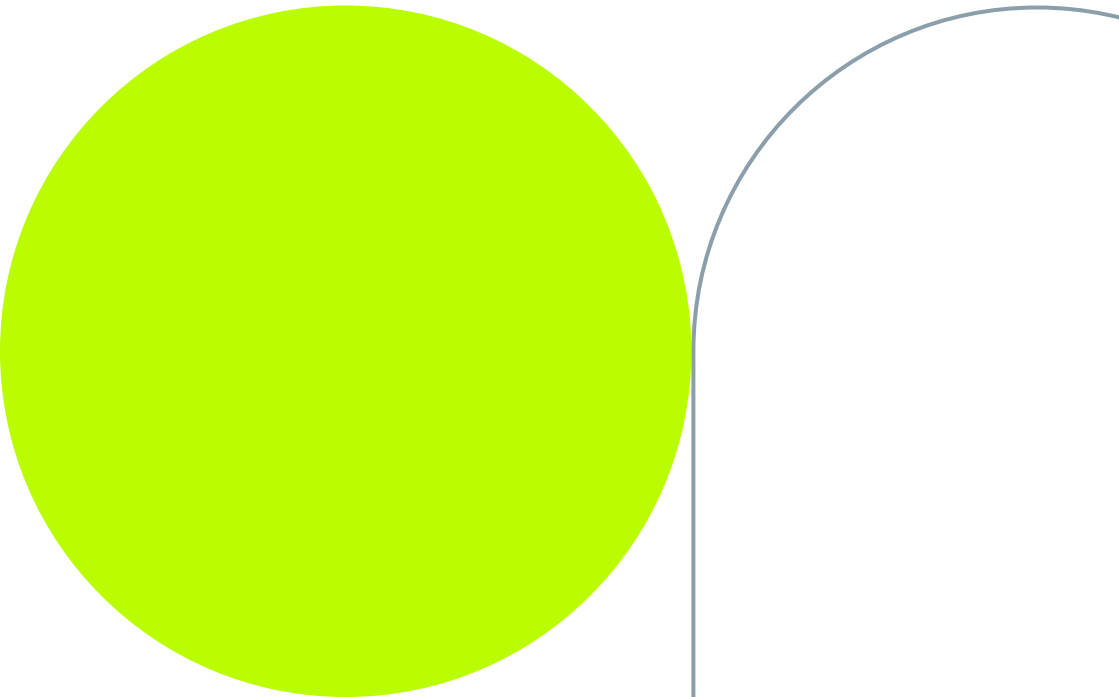

Lets get connected:

- 📷 [instagram.com/gemoneofficial](https://www.instagram.com/gemoneofficial)
- 📘 [facebook.com/gemone.telematics](https://www.facebook.com/gemone.telematics)
- 🌐 [linkedin.com/company/gemone](https://www.linkedin.com/company/gemone)
- 🐦 twitter.com/GemOne_
- ✉️ support_emea@gemone.com

www.gemone.com



©2022- GemOne NV, Spinnerijstraat 99/23, BE-8500 KORTRIJK. All rights reserved. No part of this publication may be reproduced or communicated in any form or by any means, electronic or mechanical, including copying, recording or use in an information storage or retrieval system, without prior and explicit permission of GemOne NV. Photographs and illustrations are included for reference purposes only. GemOne is a registered brand.